

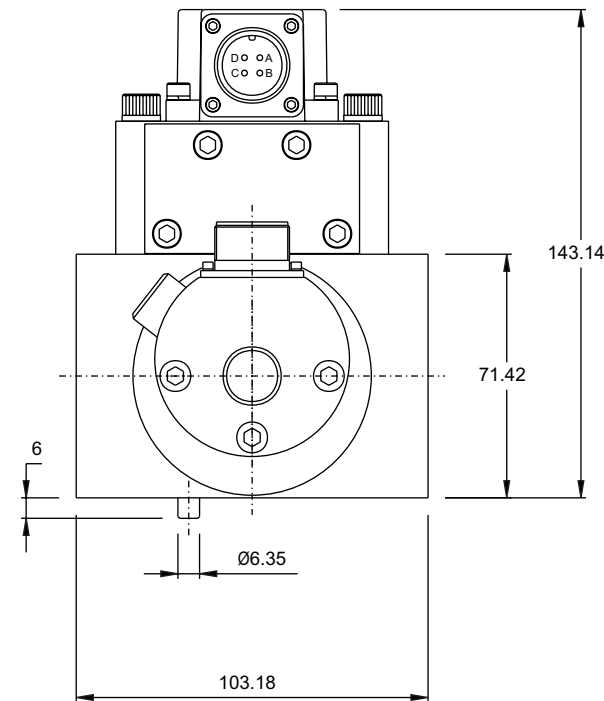

Model 60, 80

Three Stage High Response Servovalve

3/4-16 NF
x 17.5 mm deep
(both sides)
external pilot
supply & return

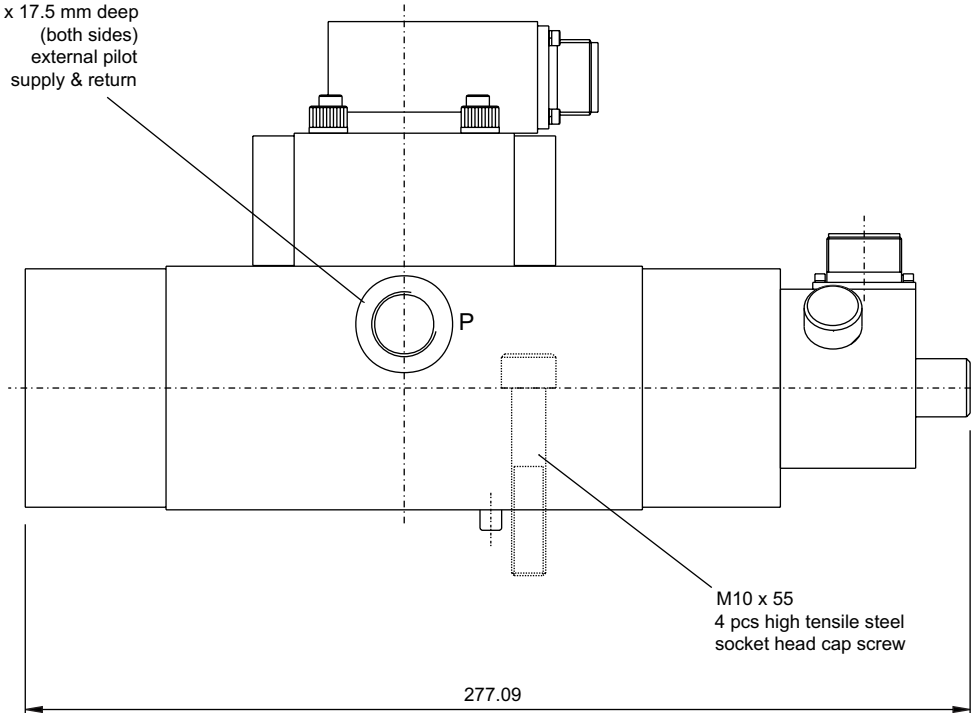

COIL CONFIGURATION

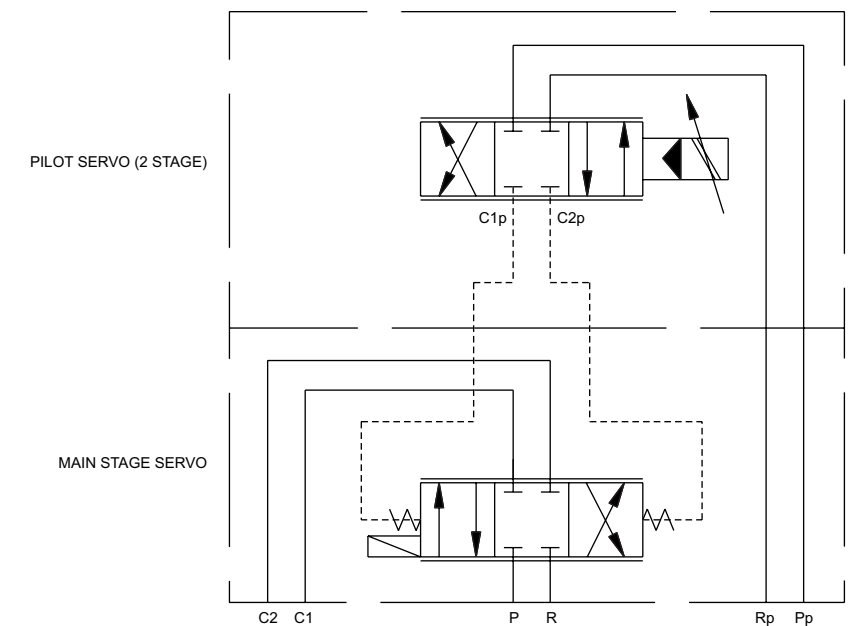
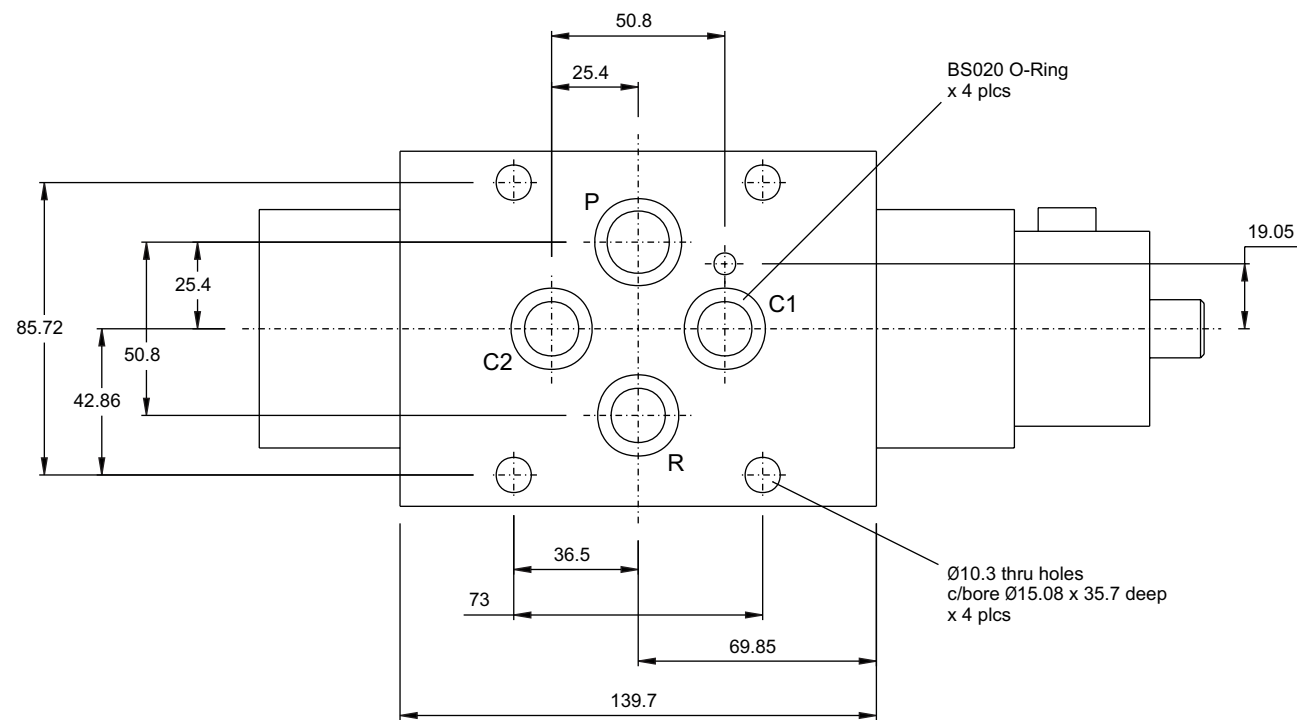
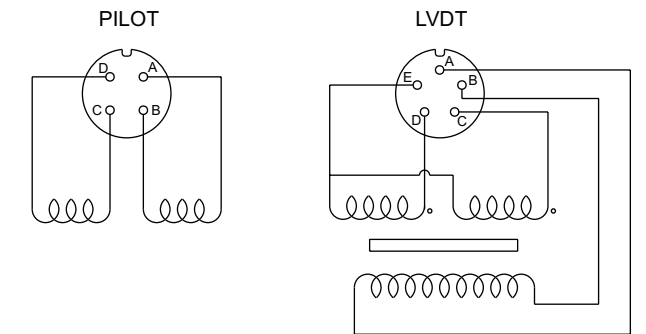



Model 60

Three Stage High Response Servovalve

Rated Flow (Qr)	230 litres/min $\pm 10\%$	70 Bar DP
Spool Diameter	20,6 mm	
Main spool drive area	333,3 mm ²	
Rated Spool Stroke	$\pm 2,5$ mm	$\pm 3,3$ mm mechanical stops
Lap Condition	0,036 mm	nominal overlap
Rated Pressure (Ps)	280 Bar	
Supply Proof Pressure	315 Bar	Control ports are the same
Return Proof Pressure	210 Bar	
Main Valve Internal Leakage	< 5,5 litres/min	140 Bar Supply Pressure
Frequency Response $\pm 100\%$ Input	550-HR -3 dB : 70 Hz 90 ° : 60 Hz	210 Bar supply pressure (typical)
Step Response	< 8 ms	for 100% output
Null Shift 30% Ps change 30 °C temp change	< 2% < 2%	
Hysteresis	< 0,5%	
Threshold	< 0,3%	
Fluid Temperature Range	0 ~ 80 °C	
Fluids	Petroleum based	
Seal Material	Nitrile 90 shore	
System Filtration	NAS 1638 class 7. ISO 4406 code 16/13	minimum
Mass	17 kg	
Pilot Valve Specification		
Rated Pressure (Psp)	210 Bar	
Model	550-HR	
Rated Flow (Qrp)	19 litres/min	70 Bar DP
Rated Input	± 40 Ma	differential
Coil Resistance	80 Ω ($\pm 10\%$)	@ ± 25 °C
Internal Leakage	< 1,2 litres/min	140 Bar supply pressure
Seal Material	Nitrile 90 shore	
LVDT Specification (alternatives available)		
Linear range	$\pm 2,5$ mm	
Sensitivity	2,43 volts/inch/volt	@ 4 KHz, 3,75 Vrms
Excitation frequency	2-4 KHz	Recommended
Excitation voltage	15 Vrms (max)	
DC Resistance	160 ohms per coil	



Model 80

Three Stage High Response Servovalve

Rated Flow (Qr)	300 litres/min $\pm 10\%$	70 Bar DP
Spool Diameter	25,4 mm	
Main spool drive area	506,7 mm ²	
Rated Spool Stroke	$\pm 2,5$ mm	$\pm 3,3$ mm mechanical stops
Lap Condition	0,036 mm	nominal overlap
Rated Pressure (Ps)	280 Bar	
Supply Proof Pressure	315 Bar	Control ports are the same
Return Proof Pressure	210 Bar	
Main Valve Internal Leakage	< 5,5 litres/min	140 Bar Supply Pressure
Frequency Response $\pm 100\%$ Input	550-HR -3 dB : 70 Hz 90 ° : 60 Hz	210 Bar supply pressure (typical)
Step Response	< 8 ms	for 100% output
Null Shift 30% Ps change 30 °C temp change	< 2% < 2%	
Hysteresis	< 0,5%	
Threshold	< 0,3%	
Fluid Temperature Range	0 ~ 80 °C	
Fluids	Petroleum based	
Seal Material	Nitrile 90 shore	
System Filtration	NAS 1638 class 7. ISO 4406 code 16/13	minimum
Mass	17 kg	
Pilot Valve Specification		
Rated Pressure (Psp)	210 Bar	
Model	550-HR	
Rated Flow (Qrp)	19 litres/min	70 Bar DP
Rated Input	± 40 Ma	differential
Coil Resistance	80 Ω ($\pm 10\%$)	@ ± 25 °C
Internal Leakage	< 1,2 litres/min	140 Bar supply pressure
Seal Material	Nitrile 90 shore	
LVDT Specification (alternatives available)		
Linear range	$\pm 2,5$ mm	
Sensitivity	2,43 volts/inch/volt	@ 4 KHz, 3,75 Vrms
Excitation frequency	2-4 KHz	Recommended
Excitation voltage	15 Vrms (max)	
DC Resistance	160 ohms per coil	



Model 130, 160H, 200H, 240H

Three Stage High Response Servovalve

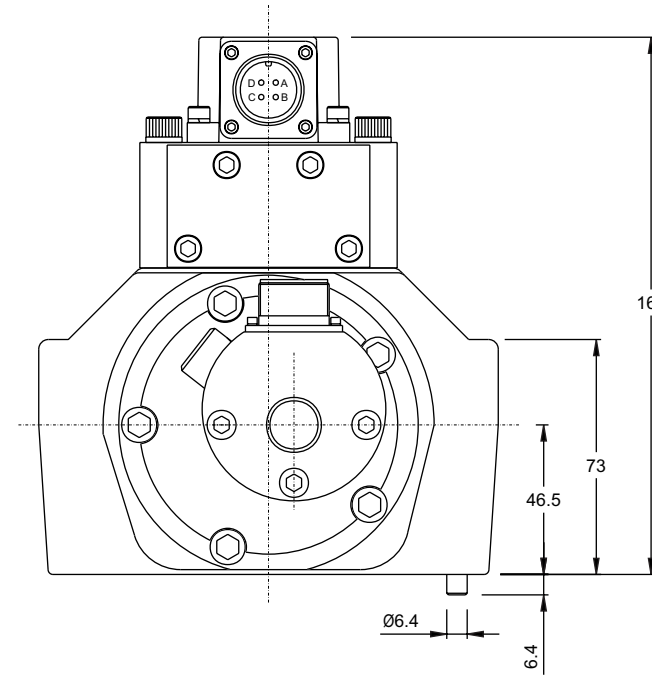
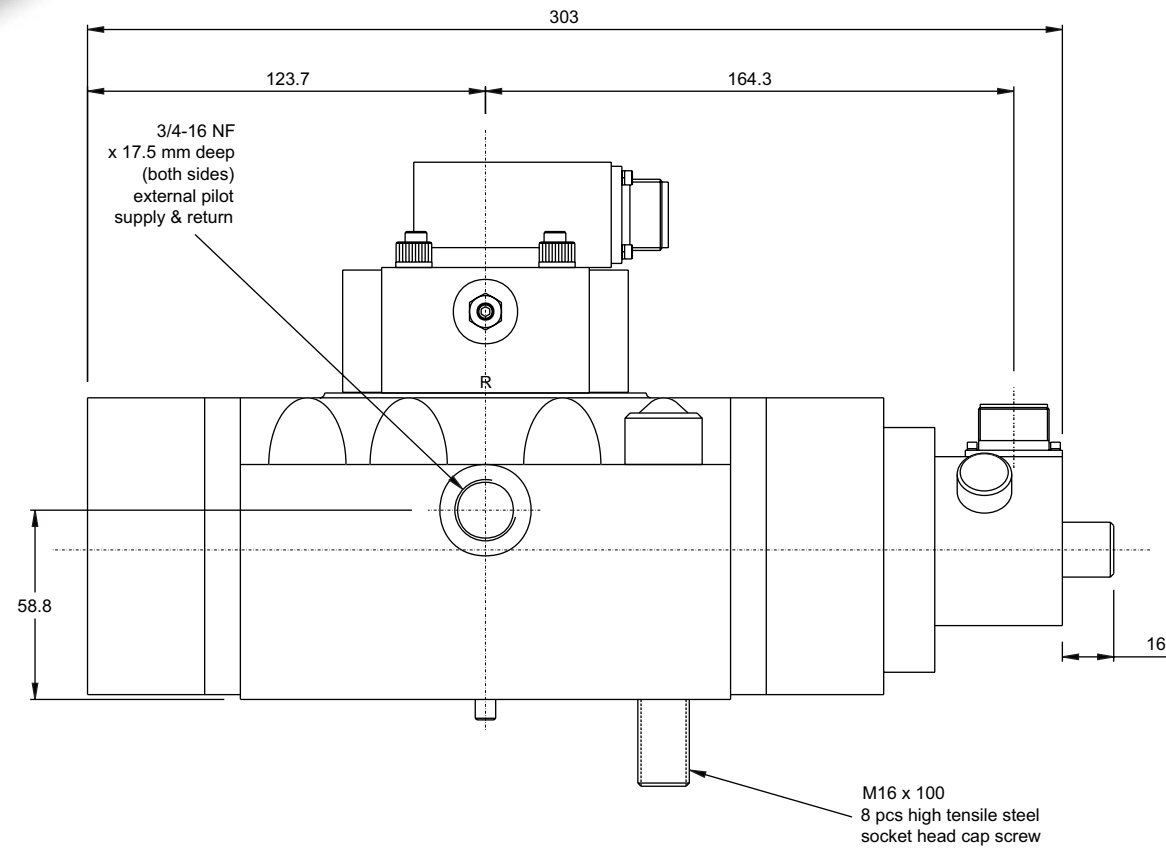

COIL CONFIGURATION

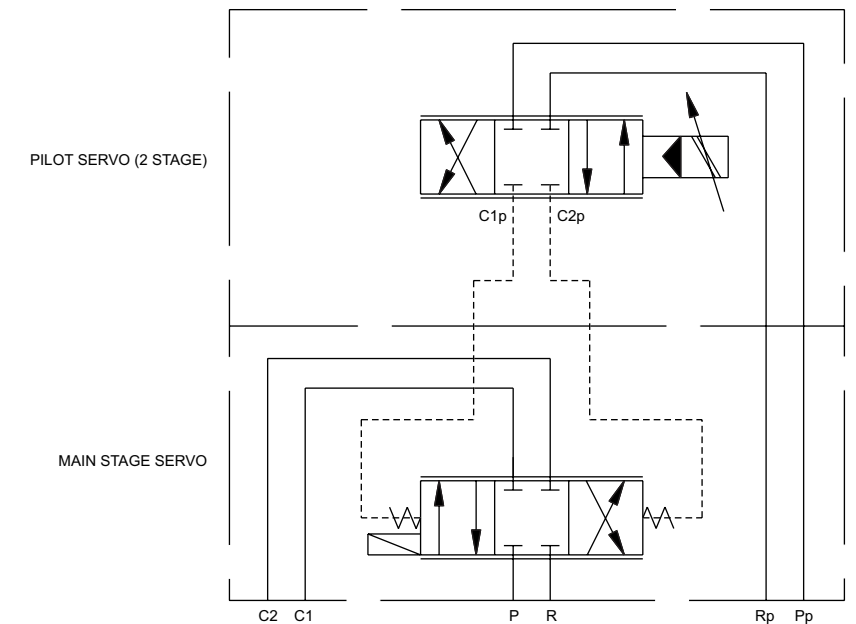
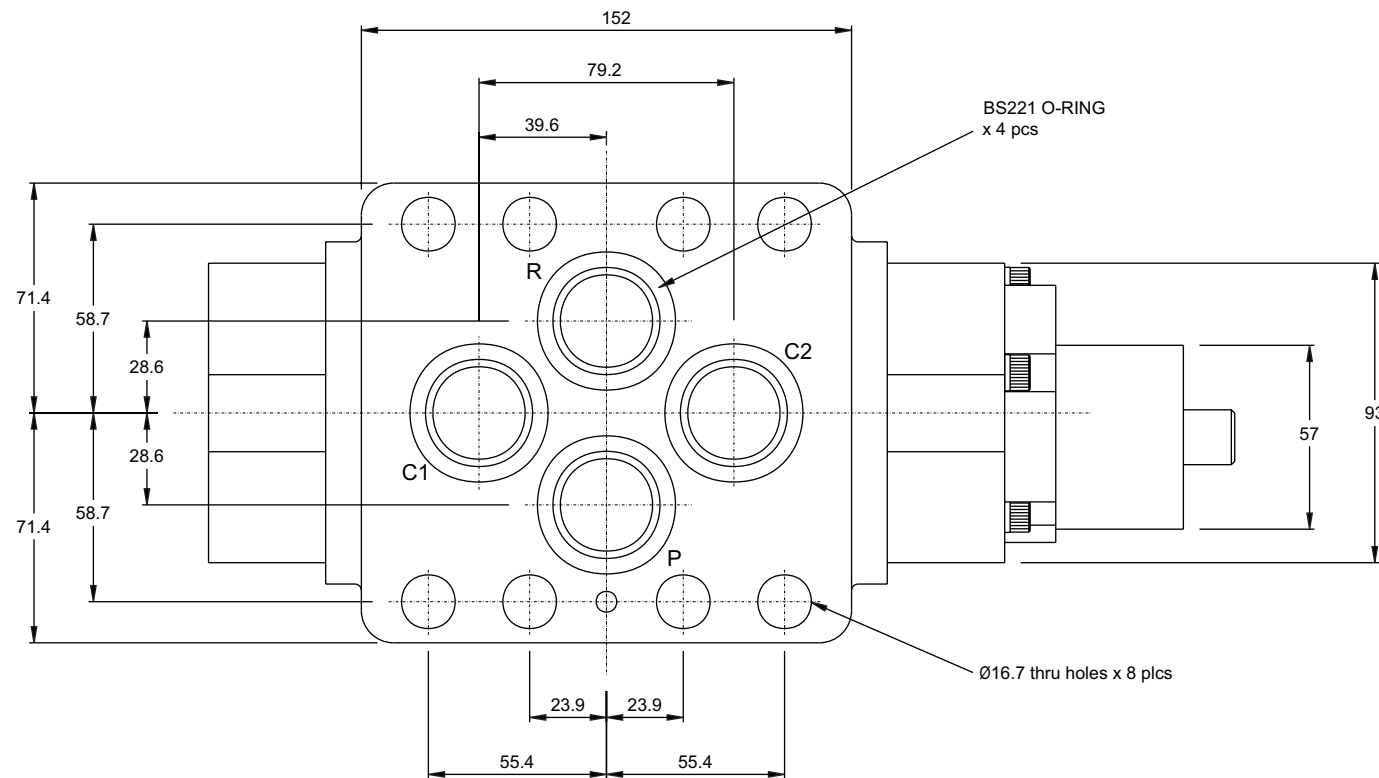
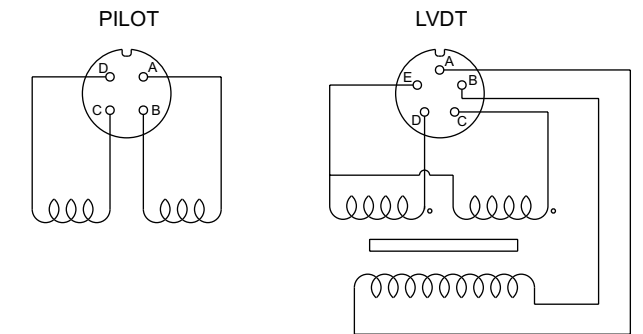



Model 130

Three Stage High Response Servovalve

Rated Flow (Qr)	490 litres/min $\pm 10\%$	70 Bar DP	
Spool Diameter	20,6 mm		
Main spool drive area	333,3 mm ²		
Rated Spool Stroke	$\pm 2,5$ mm	$\pm 3,3$ mm mechanical stops	
Lap Condition	0,036 mm	nominal overlap	
Rated Pressure (Ps)	280 Bar		
Supply Proof Pressure	315 Bar	Control ports are the same	
Return Proof Pressure	210 Bar		
Main Valve Internal Leakage	< 5,5 litres/min	140 Bar Supply Pressure	
Frequency Response $\pm 100\%$ Input	550-HR -3 dB : 70 Hz 90 ° : 60 Hz	590-VHR -3 dB : 150 Hz 90 ° : 120 Hz	210 Bar supply pressure (typical)
Step Response	< 8 ms	< 5 ms	for 100% output
Null Shift 30% Ps change 30 °C temp change	< 2% < 2%		
Hysteresis	< 0,5%		
Threshold	< 0,3%		
Fluid Temperature Range	0 ~ 80 °C		
Fluids	Petroleum based		
Seal Material	Nitrile 90 shore		
System Filtration	NAS 1638 class 7. ISO 4406 code 16/13	minimum	
Mass	17 kg		
Pilot Valve Specification			
Rated Pressure (Psp)	210 Bar		
Model	550-HR or 590-VHR		
Rated Flow (Qrp)	19 litres/min	70 Bar DP	
Rated Input	± 40 Ma	differential	
Coil Resistance	80 Ω ($\pm 10\%$)	@ ± 25 °C	
Internal Leakage	< 1,2 litres/min	140 Bar supply pressure	
Seal Material	Nitrile 90 shore		
LVDT Specification (alternatives available)			
Linear range	$\pm 2,5$ mm		
Sensitivity	2,43 volts/inch/volt	@ 4 KHz, 3,75 Vrms	
Excitation frequency	2-4 KHz	Recommended	
Excitation voltage	15 Vrms (max)		
DC Resistance	160 ohms per coil		



Model 160H

Three Stage High Response Servovalve

Rated Flow (Qr)	600 litres/min $\pm 10\%$	70 Bar DP	
Spool Diameter	25,4 mm		
Main spool drive area	285 mm ²		
Rated Spool Stroke	$\pm 2,5$ mm	$\pm 3,3$ mm mechanical stops	
Lap Condition	0,036 mm	nominal overlap	
Rated Pressure (Ps)	280 Bar		
Supply Proof Pressure	315 Bar	Control ports are the same	
Return Proof Pressure	210 Bar		
Main Valve Internal Leakage	< 5,5 litres/min	140 Bar Supply Pressure	
Frequency Response $\pm 100\%$ Input	550-HR -3 dB : 70 Hz 90 ° : 60 Hz	590-HR -3 dB : 150 Hz 90 ° : 120 Hz	210 Bar supply pressure (typical)
Step Response	< 8 ms	< 5 ms	for 100% output
Null Shift 30% Ps change 30 °C temp change	< 2% < 2%		
Hysteresis	< 0,5%		
Threshold	< 0,3%		
Fluid Temperature Range	0 ~ 80 °C		
Fluids	Petroleum based		
Seal Material	Nitrile 90 shore		
System Filtration	NAS 1638 class 7. ISO 4406 code 16/13	minimum	
Mass	17 kg		
Pilot Valve Specification			
Rated Pressure (Psp)	210 Bar		
Model	550-HR or 590-VHR		
Rated Flow (Qrp)	19 litres/min	70 Bar DP	
Rated Input	± 40 Ma	differential	
Coil Resistance	80 Ω ($\pm 10\%$)	@ ± 25 °C	
Internal Leakage	< 1,2 litres/min	140 Bar supply pressure	
Seal Material	Nitrile 90 shore		
LVDT Specification (alternatives available)			
Linear range	$\pm 2,5$ mm		
Sensitivity	2,43 volts/inch/volt	@ 4 KHz, 3,75 Vrms	
Excitation frequency	2-4 KHz	Recommended	
Excitation voltage	15 Vrms (max)		
DC Resistance	160 ohms per coil		



Model 200H

Three Stage High Response Servovalve

Rated Flow (Qr)	750 litres/min $\pm 10\%$	70 Bar DP	
Spool Diameter	30,15 mm		
Main spool drive area	285 mm ²		
Rated Spool Stroke	$\pm 2,5$ mm	$\pm 3,3$ mm mechanical stops	
Lap Condition	0,036 mm	nominal overlap	
Rated Pressure (Ps)	280 Bar		
Supply Proof Pressure	315 Bar	Control ports are the same	
Return Proof Pressure	210 Bar		
Main Valve Internal Leakage	< 5,5 litres/min	140 Bar Supply Pressure	
Frequency Response $\pm 100\%$ Input	550-HR -3 dB : 70 Hz 90 ° : 60 Hz	590-HR -3 dB : 150 Hz 90 ° : 120 Hz	210 Bar supply pressure (typical)
Step Response	< 8 ms	< 5 ms	for 100% output
Null Shift 30% Ps change 30 °C temp change	< 2% < 2%		
Hysteresis	< 0,5%		
Threshold	< 0,3%		
Fluid Temperature Range	0 ~ 80 °C		
Fluids	Petroleum based		
Seal Material	Nitrile 90 shore		
System Filtration	NAS 1638 class 7. ISO 4406 code 16/13	minimum	
Mass	17 kg		
Pilot Valve Specification			
Rated Pressure (Psp)	210 Bar		
Model	550-HR or 590-VHR		
Rated Flow (Qrp)	19 litres/min	70 Bar DP	
Rated Input	± 40 Ma	differential	
Coil Resistance	80 Ω ($\pm 10\%$)	@ ± 25 °C	
Internal Leakage	< 1,2 litres/min	140 Bar supply pressure	
Seal Material	Nitrile 90 shore		
LVDT Specification (alternatives available)			
Linear range	$\pm 2,5$ mm		
Sensitivity	2,43 volts/inch/volt	@ 4 KHz, 3,75 Vrms	
Excitation frequency	2-4 KHz	Recommended	
Excitation voltage	15 Vrms (max)		
DC Resistance	160 ohms per coil		



Model 240H

Three Stage High Response Servovalve

Rated Flow (Qr)	900 litres/min $\pm 10\%$	70 Bar DP	
Spool Diameter	36,5 mm		
Main spool drive area	285 mm ²		
Rated Spool Stroke	$\pm 2,5$ mm	$\pm 3,3$ mm mechanical stops	
Lap Condition	0,036 mm	nominal overlap	
Rated Pressure (Ps)	280 Bar		
Supply Proof Pressure	315 Bar	Control ports are the same	
Return Proof Pressure	210 Bar		
Main Valve Internal Leakage	< 5,5 litres/min	140 Bar Supply Pressure	
Frequency Response $\pm 100\%$ Input	550-HR -3 dB : 70 Hz 90 ° : 60 Hz	590-HR -3 dB : 150 Hz 90 ° : 120 Hz	210 Bar supply pressure (typical)
Step Response	< 8 ms	< 5 ms	for 100% output
Null Shift 30% Ps change 30 °C temp change	< 2% < 2%		
Hysteresis	< 0,5%		
Threshold	< 0,3%		
Fluid Temperature Range	0 ~ 80 °C		
Fluids	Petroleum based		
Seal Material	Nitrile 90 shore		
System Filtration	NAS 1638 class 7. ISO 4406 code 16/13	minimum	
Mass	17 kg		
Pilot Valve Specification			
Rated Pressure (Psp)	210 Bar		
Model	550-HR or 590-VHR		
Rated Flow (Qrp)	19 litres/min	70 Bar DP	
Rated Input	± 40 Ma	differential	
Coil Resistance	80 Ω ($\pm 10\%$)	@ ± 25 °C	
Internal Leakage	< 1,2 litres/min	140 Bar supply pressure	
Seal Material	Nitrile 90 shore		
LVDT Specification (alternatives available)			
Linear range	$\pm 2,5$ mm		
Sensitivity	2,43 volts/inch/volt	@ 4 KHz, 3,75 Vrms	
Excitation frequency	2-4 KHz	Recommended	
Excitation voltage	15 Vrms (max)		
DC Resistance	160 ohms per coil		

240He0401